



SPECIFICATION FOR APPROVAL

CUSTOMER: 寧波閃諾

EVERCOOL MODEL NO: EC1725A2HBT

CUSTOMER MODEL NO: EC1725A2HBT

DESCRIPTION: AC220V FAN

APPROVED BY (AUTHORISED)	APPROVED
	Alex
	CHECKED
	Xiongwei
	DRAWN
	Chenjie
	SALES
	Serene

* Please confirm your acceptance by return fax or mail.

SPEC NO	ISSUE DATE	EDITION	REVISED DATE
20260415J019	2026/4/15	A0(F4)	2026/4/15

THE PRODUCTION ACCORD WITH EUROPE UNION ROHS STANDARD

EVERCOOL THERMAL CO., LTD

NO. 123-8, HSING DE RD., SAN-CHUNG CITY,
TAIPEI HSIEN, TAIWAN, R.O.C.

TEL: 886-2-8512-2889 FAX: 886-2-8512-2890

[URL:www.evercool.com.tw](http://www.evercool.com.tw)

CONTENTS

(目录)

1. SCOPE (范围)	3
2. ELECTRICAL (电气特性)	3
3. MATERIAL (部件材质)	4
4. ENVIRONMENTAL (参考环境)	4
5. PROTECTION (品质保证)	4
6. REOZONE DEPLETING SUBSTANCES (环境保护)	4
7. NOISE (噪音)	5
8. RELIABILITY (可靠性测试)	5
9. OUTLINE (外形尺寸图)	6
10.NOTES (注意事项)	6

1. SCOPE (范围) :

THIS SPECIFICATION DEFINES THE ELECTRICAL AND MECHANICAL CHARACTERISTICS OF THE AC BRUSH FAN. THE FAN MOTOR IS WITH TWO PHASES AND TWO POLES.

(本承认书定义了交流式无刷风扇的电气特性和机械特性。此风扇马达为两相二极极式。)

2. ELECTRICAL (电气特性) :

ITEM	DESCRIPTION
RATED VOLTAGE (额定电压)	~220VAC
OPERATION VOLTAGE (允许电压)	~200-240VAC
Starting voltage (起动电压)	~150V (ON/OFF)
RATED CURRENT A (额定电流)	0.27A ± 10%
Locked current (锁定电流)	0.30A
INPUT POWER (输入功率)	40W ± 10%
SPEED (转速)	2550 RPM ± 10%
MAX.AIR FLOW (最大风量) (AT ZERO STATIC PRESSURE)	170CFM
MAX.AIR PRESSURE (最大风压) (AT ZERO AIRFLOW)	0.45inch-H ₂ O
ACOUSTICAL NOISE (AVG.) (平均噪音)	50dB(A)
Insulation resistance (绝缘阻抗强度)	在本体与两条导线间加 500V 直流电压之绝缘阻抗在 100M Ω 以上 At least 100M Ω at 500VDC between housing and both leadwires
Dielectric strength (绝缘耐压强度)	必须能抵抗在本体与两线间加 2000V 交流电压 2 秒 1mA。 Withstand 2000 VAC 2S 1mA between housing and both lead wires.
预期寿命 (MTBF): 指在额定电压及正常温度, 湿度条件下连续运转 Life expectance: continuous operation at rated voltage and normal temperature & humidity	滚珠轴承预期寿命: 30000 小时 Ball bearing life expectance: 30000h

3. MECHANICAL (部件材质):

3-1.DIMENSIONS (尺寸) SEE DIMENSIONS DRAWING (参考尺寸图画)

3-2.FRAME (框) 铝合金烤漆

3-3.IMPELLER (扇叶) P B T. UL94V-0 (防火料 94V-0)

3-4.BEARING SYSTEM (轴承类别) BALLBearing (滚珠轴承)

3-5.WEIGHT (重量) GRAMS (820G)

4.NVIRONMENTAL (参考环境):

4-1.OPERATING TEMPERATURE (运行温度) -10 TO +70 DEGREE C

4-2.STORAGE TEMPERATURE (储存温度) -30 TO +80 DEGREE C

4-3.OPERATING HUMIDITY (运行湿度) 5 TO 90% RH

4-4.STORAGE HUMIDITY (储存湿度) 5 TO 95% RH

5.ROTECTION (品质保证):

5-1.DROP TEST (落体试验)

IN MINIMUM PACKAGING CONDITION FAN WITHSTANDS EACH ONE-DROP OF THREE FACES FROM 30 CM DISTANCE HEIGHT ONTO 10 MM THICKNESS OF WOODEN BOARD.

(在正常的包装情况下, 风扇能够经受将整体包装的三个面分别从 30cm 高度跌落至 10cm 厚的木版上, 风扇将安然无恙。)

5-2.LOCKED ROTOR PROTECTION (转子锁定保证)

IMPEDANCE OF MOTOR WINDING PROTECTS MOTOR FROM FIRE IN 24 HOURS OF LOCKED ROTOR CONDITION AT THE RATED VOLTAGE.

(在通入额定电压的情况下, 将转子锁定烧机测试 24 小时, 马达线圈绕组将不会被烧坏。)

6.RE OZONE DEPLETING SUBSTANCES (环保):

6-1.NO CONTAINING PBBs, PBBOs, CFCs, PBBEs, PBDPEs AND HCFCs.

(不会产生对臭氧破坏的 PBBs, PBBOs, CFCs, PBBEs, PBDPEs 和 HCFCs 等物质。)

11.OUTLINE (外形尺寸图)

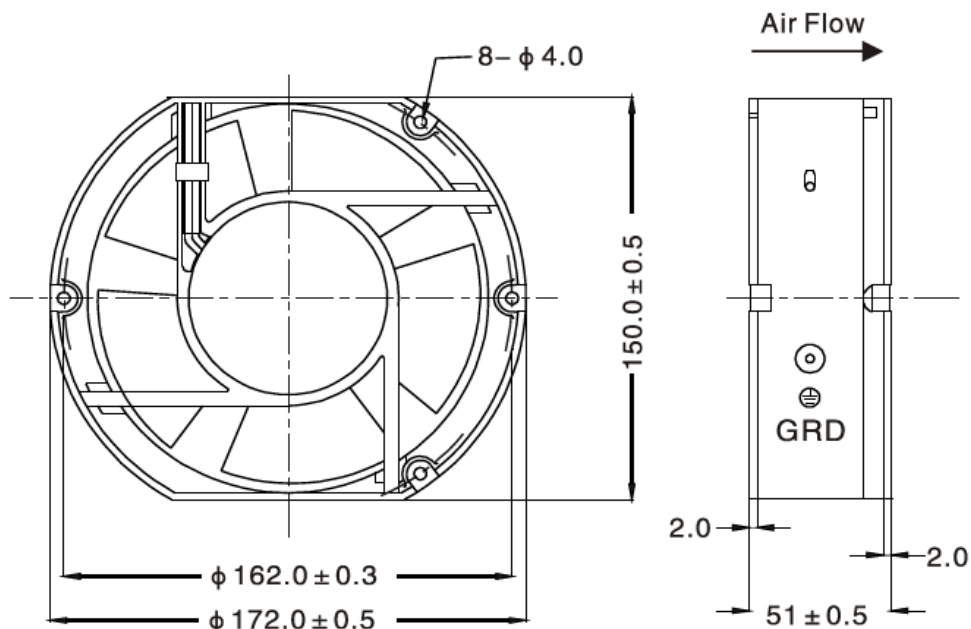

12.NOTES (注意事项)

12.1 Please do not touch the impeller and never carry the fan the lead wires. The bearings and the lead wires may be damaged.

(请不要碰触扇叶和拉扯线材，以免损坏轴承及导线。)

12.2 For the purpose of MIS, please specify the Model No. on every order.

(便于订单管理，请在每一订单上详细注明其型号。)

12.3 Please do not use the fan in the environment of corrosive gas or liquid.

(请不要将风扇置于腐蚀的气体 and 液体内。)

12.4 Please do not store the fan in the environment of high humidity. Please avoid storage of the fan over 6 months . For long term storage, please connect power to the fan shortly every 6 months even through the fan is stored in room temperature.

(请不要将风扇储存在高湿度的环境中，请尽量避免将风扇储存期超过 6 个月。如果要长期储存，请将其在室温的环境下，且每隔 6 个月须通上电源让风扇短时间运转。)

12.5 While the fan is in operation, please do not lock the fan intentionally for a long period of time to prevent over heating which may cause permanent damage.

(当风扇在正常运转时，请不要长时间故意地锁定风扇，那样会使风扇过热从而有可能导致风扇的永久性损坏。)